

Industrial Gas Valves

GSV & GSHV Series

Global Industrial Gas Valves



GSV58061-XX

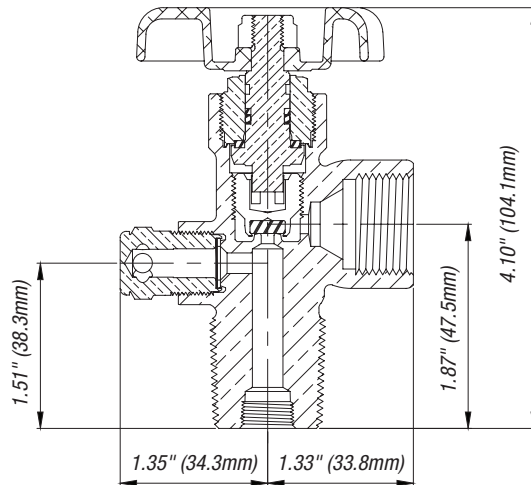

GSV Series
Up to 3500 PSI Working Pressure



GSHV70361-XX

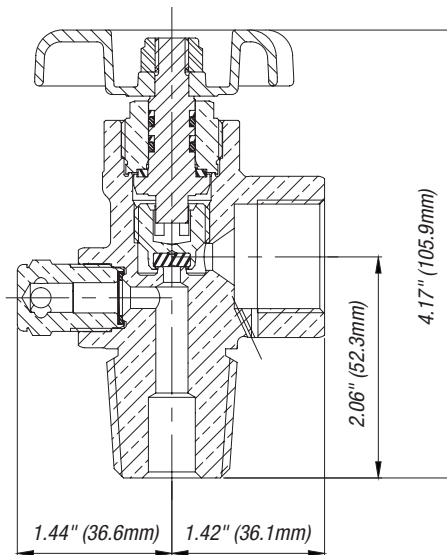

GSHV Series
Up to 6400 PSI Working Pressure

Designed for use in every country around the world. For use in cylinders containing oxygen, argon, carbon dioxide, nitrogen, helium and hydrogen, as well as welding gas mixtures.

Key Features & Benefits

- Automated assembly and testing processes ensure exceptional quality
- 100% helium leak tested
- Heavy-duty forged brass body for durability and high pressure
- Precisely machined internal components meet the most stringent international valve performance standards
- Pressure Relief Device (PRD) is a unitized plug design that provides excellent flow characteristics, ensures proper assembly and tamper resistance
- Improved metal-to-metal seal below bonnet threads prevents pressure in the threads at top of valve body
- Direct-drive stem design with optimized O-ring (GSV) or double O-ring (GSHV) seal reduces friction and operates at exceptionally low torque levels
- Inlet and outlet thread configurations are available for a broad spectrum of customer, country and code specifications
- Inlet tapped (1/4" NPT) for dip tube as required

For Product Markings Reference, see **A** in the Appendix

GSV & GSHV Series

Global Industrial Gas Valves

For further ordering information, refer to the Selection of Pressure Relief Devices, the Pressure Relief Device Numbering Matrix, and the Valve Part Numbering Matrix.

Ordering Information					
Sherwood Part Number	Gas Service @ 70° F	CGA Outlet	Outlet Thread Size	Inlet Thread Size	
<i>Carbon Dioxide</i>					
GSV32041-XX	0 PSI–3000 PSI	320	.825–14 NGO RH Ext.	½" NGT	
GSV32061-XX	0 PSI–3000 PSI	320	.825–14 NGO RH Ext.	¾" NGT	
GSV32081-XX	0 PSI–3000 PSI	320	.825–14 NGO RH Ext.	1" NGT	
GSV32025E1-XX	0 PSI–3000 PSI	320	.825–14 NGO RH Ext.	25E ISO	
GSV32051-XX-75	0 PSI–3000 PSI	320	.825–14 NGO RH Ext.	.750–16 UNF	
GSV32051-XX	0 PSI–3000 PSI	320	.825–14 NGO RH Ext.	1.125–12 UNF	
<i>Nitrous Oxide</i>					
GSV32641-XX	0 PSI–3000 PSI	326	.825–14 NGO RH Ext.	½" NGT	
GSV32661-XX	0 PSI–3000 PSI	326	.825–14 NGO RH Ext.	¾" NGT	
GSV32681-XX	0 PSI–3000 PSI	326	.825–14 NGO RH Ext.	1" NGT	
GSV32625E1-XX	0 PSI–3000 PSI	326	.825–14 NGO RH Ext.	25E ISO	
GSV32651-XX-75	0 PSI–3000 PSI	326	.825–14 NGO RH Ext.	.750–16 UNF	
GSV32651-XX	0 PSI–3000 PSI	326	.825–14 NGO RH Ext.	1.125–12 UNF	
<i>Air</i>					
GSV34641-XX	0 PSI–3000 PSI	346	.825–14 NGO RH Ext.	½" NGT	
GSV34661-XX	0 PSI–3000 PSI	346	.825–14 NGO RH Ext.	¾" NGT	
GSV34681-XX	0 PSI–3000 PSI	346	.825–14 NGO RH Ext.	1" NGT	
GSV34625E1-XX	0 PSI–3000 PSI	346	.825–14 NGO RH Ext.	25E ISO	
GSV34651-XX-75	0 PSI–3000 PSI	346	.825–14 NGO RH Ext.	.750–16 UNF	
GSV34651-XX	0 PSI–3000 PSI	346	.825–14 NGO RH Ext.	1.125–12 UNF	
GSVH34761-XX	3001 PSI–4700 PSI	347	.825–14 NGO RH Ext.	¾"–14 NGT	
GSVH70261-XX	4701 PSI–6400 PSI	702	1.125–14 NGO RH Int.	¾"–14 NGT	
<i>Carbon Monoxide and Hydrogen</i>					
GSV35045-XX	0 PSI–3000 PSI	350	.825–14 NGO LH Ext.	½" NGT	
GSV35065-XX	0 PSI–3000 PSI	350	.825–14 NGO LH Ext.	¾" NGT	
GSV35085-XX	0 PSI–3000 PSI	350	.825–14 NGO LH Ext.	1" NGT	
GSV35025E5-XX	0 PSI–3000 PSI	350	.825–14 NGO LH Ext.	25E ISO	
GSV35055-XX-75	0 PSI–3000 PSI	350	.825–14 NGO LH Ext.	.750–16 UNF	
GSV35055-XX	0 PSI–3000 PSI	350	.825–14 NGO LH Ext.	1.125–12 UNF	
GSVH69565-XX	3001 PSI–4700 PSI	695	1.045–14 NGO LH Int.	¾"–14 NGT	
GSVH70365-XX	4701 PSI–6400 PSI	703	1.125–14 NGO LH Int.	¾"–14 NGT	
<i>Oxygen</i>					
GSV54041-XX	0 PSI–3000 PSI	540	.903–14 NGO RH Ext.	½" NGT	
GSV54061-XX	0 PSI–3000 PSI	540	.903–14 NGO RH Ext.	¾" NGT	
GSV54081-XX	0 PSI–3000 PSI	540	.903–14 NGO RH Ext.	1" NGT	
GSV54051-XX-75	0 PSI–3000 PSI	540	.903–14 NGO RH Ext.	.750–16 UNF	
GSV54051-XX	0 PSI–3000 PSI	540	.903–14 NGO RH Ext.	1.125–12 UNF	
GSVH57761-XX	3001 PSI–3500 PSI	577	.960–14 NGO RH Ext.	¾" NGT	
GSVH70161-XX	3501 PSI–4700 PSI	701	1.103–14 NGO RH Ext.	¾" NGT	
<i>Argon, Helium, Krypton, Neon, Nitrogen and Xenon</i>					
GSV58041-XX	0 PSI–3000 PSI	580	.965–14 NGO RH Int.	½" NGT	
GSV58061-XX	0 PSI–3000 PSI	580	.965–14 NGO RH Int.	¾" NGT	
GSV58081-XX	0 PSI–3000 PSI	580	.965–14 NGO RH Int.	1" NGT	
GSV58025E1-XX	0 PSI–3000 PSI	580	.965–14 NGO RH Int.	25E ISO	
GSV58051-XX-75	0 PSI–3000 PSI	580	.965–14 NGO RH Int.	.750–16 UNF	
GSV58051-XX	0 PSI–3000 PSI	580	.965–14 NGO RH Int.	1.125–12 UNF	
GSVH68061-XX	3001 PSI–4700 PSI	680	1.045–14 NGO RH Int.	¾" NGT	
GSVH67761-XX	4701 PSI–6400 PSI	677	1.030–14 NGO LH Ext.	¾" NGT	
<i>Sulfur Hexafluoride</i>					
GSV59041-XX	0 PSI–3000 PSI	590	.965–14 NGO LH Int.	½" NGT	
GSV59061-XX	0 PSI–3000 PSI	590	.965–14 NGO LH Int.	¾" NGT	
GSV59081-XX	0 PSI–3000 PSI	590	.965–14 NGO LH Int.	1" NGT	
GSV59025E1-XX	0 PSI–3000 PSI	590	.965–14 NGO LH Int.	25E ISO	
GSV59051-XX-75	0 PSI–3000 PSI	590	.965–14 NGO LH Int.	.750–16 UNF	
GSV59051-XX	0 PSI–3000 PSI	590	.965–14 NGO LH Int.	1.125–12 UNF	

Oversize Inlets: 4 & 7 and 24 thread oversize inlets: To order add -4, -7 or -24 to the end of the Part Number. For example GSV34661-XX becomes GSV34661-XX-7

Chrome plating: To order, add letter "A" after the letters GSV or GSHV in the Part Number. For example GSV34661-XX becomes GSVA34661-XX

Lexan polycarbonate handwheels: To order, add suffix LX to end of Part Number. For example GSV34661-XX becomes GSVA34661-XXLX

Fusible back pressure relief devices: For 165° F or 212° F nominal melting temperatures, change 1 in the Part Number to 4 (165° F) or 5 (212° F) (ie. GSV35061-XX becomes GSV35064-XX for 165° F, or GSV35065-XX for 212° F.

Industrial Gas Valves

GSV

Global Industrial Gas Valves

Design Specifications		
	English	Metric
Maximum Working Pressure	3500 PSI	241 Bar
Burst Pressure	10,000 PSI	689 Bar
Operating Temperature Range	-50° F to +149° F	-45° C to +65° C
Storage Temperature Range	-65° F to +155° F	-54° C to +68° C
Leak Rate Internal/External	1x10 ⁻³ atm cc/sec.	1x10 ⁻³ Bar mL/sec.
Minimum Cycle Life	2000 Cycles	
Cv Flow Factor	Standard: .690 CO ₂ /Manifold: 1.23	
Closing Torque	20–30 in.-lbs.	2.2–3.3 N-m
Operating Torque	10–20 in.-lbs.	1.1–2.2 N-m
Bonnet Installation Torque	50–60 ft.-lbs.	68–81 N-m
Handwheel Nut Installation Torque	25–45 in.-lbs.	2.8–5.2 N-m
PRD Installation Torque	25–35 ft.-lbs.	34–47 N-m
PRD Flow Capacity	60 cfm @ 100 PSI	1700 L/min. @ 6.9 Bar

Part Description	Materials of Construction
Body	Forged Brass C37700; Chrome Plating When Applicable
Bonnet	Brass C36000; Chrome Plating When Applicable
Handwheel	Aluminum A380
Handwheel Nut	Steel Class 8, Zinc Plating
Lower Plug	Brass C48500
Lower Plug Seat	Nylon Zytel 101
Lubricant	Christo-Lube
Pressure Relief Device	
Plug	Brass C36000; Chrome Plating When Applicable
Rupture Disc	Nickel Alloy 201; Copper C22000
Seal Gasket	Copper C11000
Stem	Brass C36000
O-Ring	Ethylene Propylene (EPDM)
Back-up O-Ring	Ethylene Propylene (EPDM)
Thrust Washer	Delrin® 500 AF

NOTE: GSV Series valves are not for use with CNG applications. For CNG Service, see NGV and NGVHM Series. No mechanical addition of force is to be used with handwheel-style valves without the use of controlled torque.

Standards Conformance	
CGA V-9	Standard for Gas Cylinder Valves
CGA S1.1	Standard for Pressure Relief Devices
CGA V-1	Compressed Gas Cylinder Valve Outlet and Inlet Specifications
ISO 10297	International Standard for Cylinder Valves Design Specifications
ISO 11363-1	25E Inlet Thread Specifications
A-A-59860	U.S. General Services Administration Standards for Gas Cylinder Valves

Inlet O-Ring for Straight Threaded GV Valves			
Sherwood Part Number	Size	Material	Quantity
G907APK	.625 UNF	Buna-N	50
G210A-9PK	.750 UNF	Buna-N	50
G216BPK	1.125 UNF	Buna-N	100
G016TPK	.625 UNF	PTFE	50
G210TPK	.750 UNF	PTFE	100
P1100X15-20TPK	1.125 UNF	PTFE	50

Replacement Parts		
Sherwood Part Number	Description	Quantity
1251-6PK	Handwheel Nut	100
1919APK	Handwheel	200
P625-19X9-XXPK	Pressure Relief Device Unitized Assembly Includes Plug, Rupture Disc and Webbed Seal Washer	100

GSHV Series

Global Industrial Gas Valves

Design Specifications		
	English	Metric
Maximum Working Pressure	6400 PSI	413 Bar
Burst Pressure	13,500 PSI	931 Bar
Operating Temperature Range	-50° F to +149° F	-45° C to +65° C
Storage Temperature Range	-65° F to +155° F	-54° C to +68° C
Leak Rate Internal/External	1x10 ⁻⁴ atm cc/sec.	1x10 ⁻⁴ Bar mL/sec.
Minimum Cycle Life	2000 Cycles	
Cv Flow Factor	Standard: .690	
Closing Torque	20–30 in.-lbs.	2.2–3.3 N-m
Operating Torque	10–20 in.-lbs.	1.1–2.2 N-m
Bonnet Installation Torque	60–70 ft.-lbs.	81–95 N-m
Handwheel Nut Installation Torque	25–45 in.-lbs.	2.8–5.2 N-m
PRD Installation Torque	40–50 ft.-lbs.	54– 68 N-m
PRD Flow Capacity	60 cfm @ 100 PSI	1700 L/min. @ 6.9 Bar

Standards Conformance	
CGA V-9	Standard for Gas Cylinder Valves
CGA S1.1	Standard for Pressure Relief Devices
CGA V-1	Compressed Gas Cylinder Valve Outlet and Inlet Specifications
ISO 10297	International Standard for Cylinder Valves Design Specifications
ISO 11363-1	25E Inlet Thread Specifications
A-A-59860	U.S. General Services Administration Standards for Gas Cylinder Valves

Materials of Construction	
Part Description	Materials of Construction
Body	Forged Brass C37700; Chrome Plating When Applicable
Bonnet	Brass C36000; Chrome Plating When Applicable
Handwheel	Aluminum A380
Handwheel Nut	Steel Class 8, Zinc Plating
Lower Plug	Brass C48500
Lower Plug Seat	Nylon Zytel 101
Lubricant	Christo-Lube/Turmoxygen for oxygen service
Pressure Relief Device Plug Rupture Disc Seal Gasket	Brass C36000; Chrome Plating When Applicable Nickel Alloy 201; Copper C22000 Copper C11000
Stem	Brass C36000
O-Ring	Ethylene Propylene (EPDM)
Back-up O-Ring	Ethylene Propylene (EPDM)
Thrust Washer	Delrin® 500 AF

NOTE: GSV & GSVH Series valves are not for use with CNG applications. For CNG Service, see NGV and NGVHM Series. No mechanical addition of force is to be used with handwheel-style valves without the use of controlled torque.

Replacement Parts		
Sherwood Part Number	Description	Quantity
1251-6PK	Handwheel Nut	100
1919APK	Handwheel	200
P625-19X9H-XXPK	Pressure Relief Device Unitized Assembly Includes Plug, Rupture Disc and Webbed Seal Washer	50